



## FHT 1388 S

Modular Radiation Portal Monitors

The modular FHT 1388 S radiation portal monitors secure sites against the movement of contaminated material and orphan sources.

It is a proven radiation portal monitor in the European steel and recycling market. Our qualified Service Team and Service Partners are at call to maintain the performance and reliability of the FHT 1388 S monitors.

Since the introduction in 1995, the FHT 1388 series of radiation portal monitors have been periodically updated to keep up with market needs and technological developments.

Hundreds of installations in Europe and around the world provide protection against radioactive contamination day in and day out.



- Large plastic scintillation detectors for gamma radiation detection
- Immediate separation between NORM and artificial radiation through NBR (Natural Background Rejection) technology
- Optional moderated He-3 counting tube Neutron radiation detectors
- Effective false alarm suppression through automatic background radiation learning and SIGMA alarm threshold setting
- Recognition of objects plus speed alarm triggering
- Control of traffic lights, audible alarm indication via horn or visible via alarm lights
- Data transfer via RS 485 from the detector array to the operators room up to 1000 m
- Win XP based controller model FHT 8000 with 32 bit SGS2 software package
- Automated protocol printing also on a network printer
- Optional LAN video camera can easily integrated
- Optional axle counter insures alarm location information also for most demanding train applications



The FHT 1388 S detector panels are equipped with large area plastic scintillators for the efficient detection of gamma radiation. The panel housings are made of UV-stabilized PE material that is corrosion free even under demanding conditions. Low energetic radiation can penetrate through the PE material easily and is not shielded from the sensitive large area gamma radiation detector.

advanced software package SGS2.EXE allows protected access on different user levels. Features like the FHT 8000's build-in Ethernet card or optional supervision software for up to 10 FHT 1388 S monitors underline this modern monitoring concept.

The detector panel array communicates with the electronics in the operator's room via a reliable RS 485 data bus over up to 1000 m. The modern design of the electronics comprising our controller model FHT 8000, operating Microsoft Windows XP. The



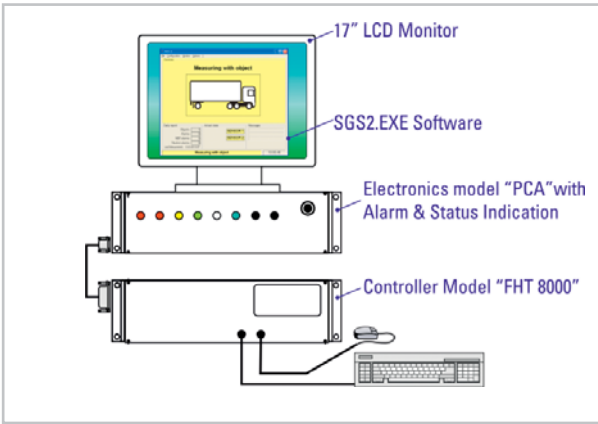

Standard supply of electronics for the operator's room.  
(FHT 1388 S versions 1460 G VER, 3000 G VER & HOR, 6000 G HOR)

**Technical Specifications:**

Operating conditions for the electronics in the operator's room:  
Ambient temperature range: 0 °C ... 40 °C, (32 °F ... 104 °F)  
Relative air humidity: 10% to 90% (not condensing)

Operating conditions for the equipment at the detector array:  
Ambient temperature range: - 40 ... 60 °C, (- 40 ... 140 °F)

Measured value:  
Gamma radiation from approx. 40 keV

Available options:  
Video camera (LAN), axle counter (train), protocol printer, modem for tele service, traffic lights (red & green), extra panels (gamma & neutron), lead shielding, alarm devices (sound & light), gamma test adapter (panel and system performance test), stanchions & installation.

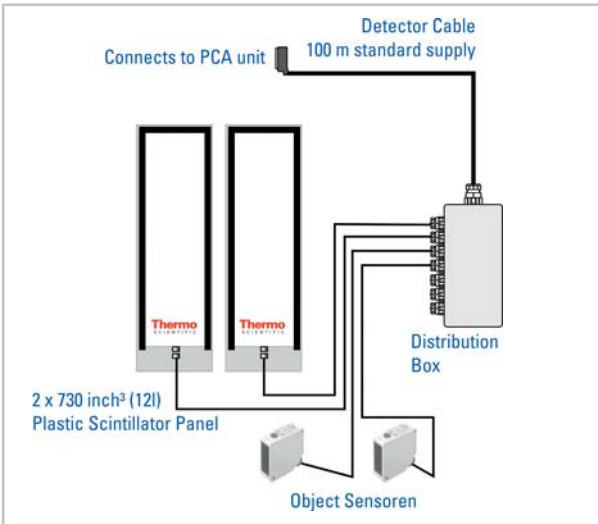

FHT 1388 S 1460 G VER: Standard equipment for the detector array

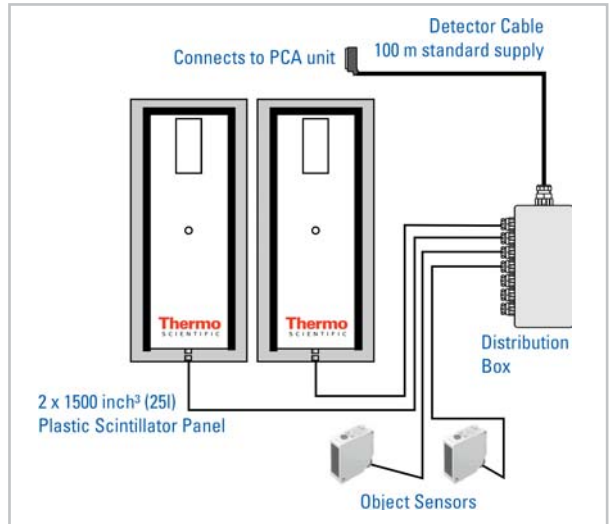

FHT 1388 S 3000 G VER: Standard equipment for the detector array

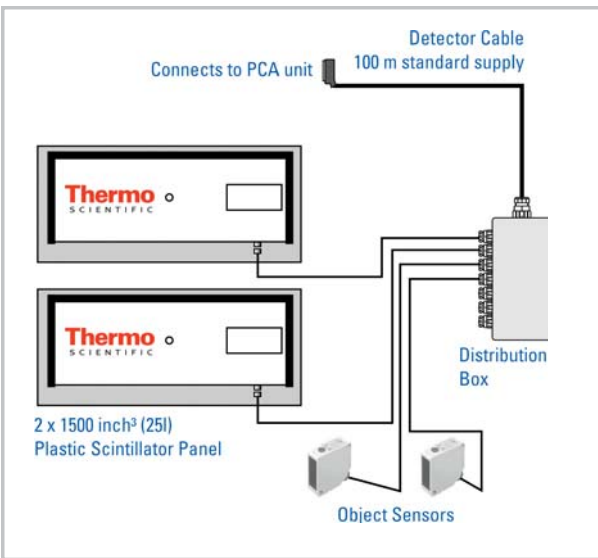

FHT 1388 S 3000 G HOR: Standard equipment for the detector array

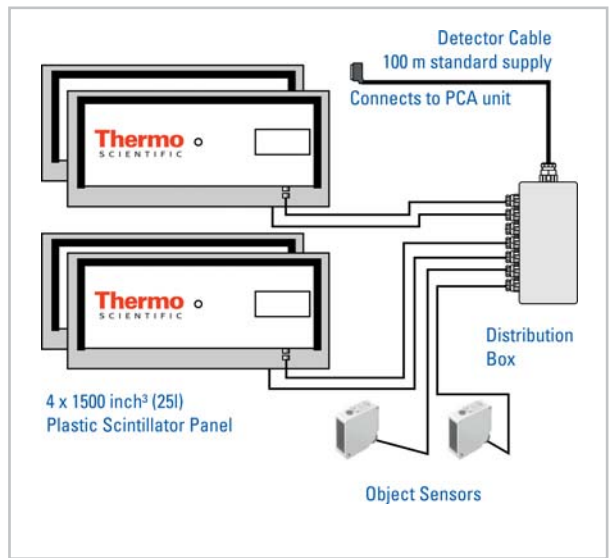

FHT 1388 S 6000 G HOR: Standard equipment for the detector array

This specification sheet is for informational purposes only and is subject to change without notice. Thermo makes no warranties, expressed or implied, in this product summary.  
© 2008 Thermo Fisher Scientific Inc. All rights reserved. FHT1388S-e-V1.1\_14March08